



# COMBiLiFT

Customised Handling Solutions

## COMBi<sup>®</sup>-CB

Compact multi-directional forklift



Long Load Handling



Inside Container



Bottom Level Storage



Sliding LP Gas Bottle



- > Handles Palletised & Long Loads
- > Operates Indoors & Outdoors

[www.COMBiLiFT.com](http://www.COMBiLiFT.com)



# SPECIFICATIONS

# COMBi<sup>®</sup>-CB

Protected by Design Registration Copyright: *European Community No.: 000725668-0001 | US No.: D579, 624 | Canadian No.: 123292 | Australian No.: 318370 | Russian Federation No.: 70814 | Korean No.: 30-0516087 | Japanese No.: 1330896 | Taiwan No.: D126056 | Chinese No.: ZL200730329732.6*

DESCRIPTION		STD	OPTIONAL		
1a	Standard Lift Height	4000mm	4900mm	5500mm	6000mm
1b	Free Lift Height	0	1318mm	1518mm	1718mm
2	Height Mast Closed	2670mm	2243mm	2443mm	2643mm
3	Max. (Mast Raised)	4830mm	5778mm	6378mm	6878mm
4	Overall Length		2615mm		
5	Ground Clearance Under Mast		125mm		
6	Ground Clearance to Wheelbase Centre		100mm		
7	Height of Overhead Guard		2250mm		
8	Width		1500mm		
9	Outside Spread of Fork Arms		1325mm		
10	Track Front		1320mm		
11	Load Centre Distance		600mm		
12	Overhang Front		300mm		
13	Wheel Base		1100mm		
14	Overhang Back		140mm		
15	Length From Face of Fork		1550mm		
16	Approach Angle		30°		
17	Ramp Angle		15°		
18	Departure Angle		30°		
19	Forward Tilt		3°		
20	Backward Tilt		8°		
21	Minimum Outside Radius		1500mm		
A	Capacity		2500Kg		
B	Unladed Weight		5900Kg		
C	Maximum Ground Speed		12 Km/h		
D	Gradability		10%		
E	V1505 Kubota diesel / 3.0L GM LP Gas		32KW / 48KW		
F	Electrics		12 Volt		
G	Fork Section		125 x 50 x 1065mm		
H	16 x 7 - 10.5 Front Rubber Tyre x 2		OD 406 / Width 178		
I	22 x 10 x 16 Rear Rubber Tyre x 1		OD 559 / Width 254		
J	Standard Colour		Green and Grey		
K	Suspension Seat		KAB Model 211		

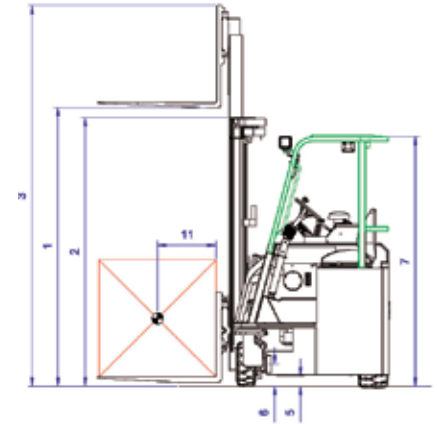

**SIDEWARD MODE**

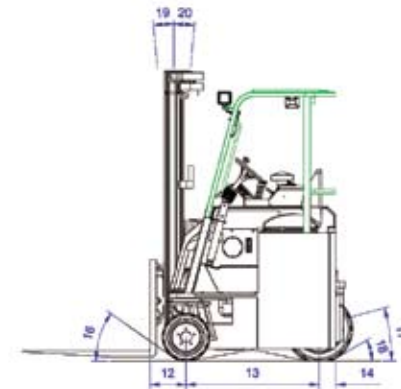
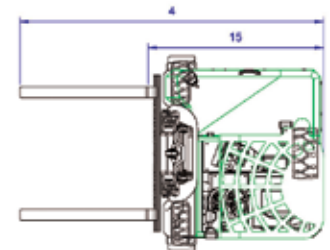

**FRONTAL MODE**



**FEATURES INCLUDE:**

- Open Cabin
- Load Sensing Steering
- 4-way lever positioning of Wheels
- Multi-direction Operation
- 3 Wheel Hydrostatic Drive
- 200mm Side Shift
- Automatic Carousel

Distributed by

[www.COMBiLiFT.com](http://www.COMBiLiFT.com)

**COMBiLiFT**

Co. Monaghan  
Ireland

T: +353 47 80500

F: +353 47 80501

E: info@combilift.com



# COMBiLiFT

Customised Handling Solutions

## COMBi<sup>®</sup>-CB4

Compact multi-directional forklift



- > Handles Palletised & Long Loads
- > Operates Indoors & Outdoors

[www.COMBiLiFT.com](http://www.COMBiLiFT.com)



# SPECIFICATIONS

# COMBi<sup>®</sup>-CB4

Protected by Design Registration Copyright: *European Community No.: 000725668-0001 | US No.: D579, 624 | Canadian No.: 123292 | Australian No.: 318370 | Russian Federation No.: 70814 | Korean No.: 30-0516087 | Japanese No.: 1330896 | Taiwan No.: D126056 | Chinese No.: ZL200730329732.6*

Ref.	DESCRIPTION	STANDARD
1 a	Max. Lift Height	4040mm
1 b	Free Lift Height	0mm
2	Height Mast Closed	2900mm
3	Max. (Mast raised)	5050mm
4	Overall Length	3028mm
5	Ground Clearance Under Mast	152mm
6	Ground Clearance to Wheelbase Centre	152mm
7	Height of Overhead Guard	2356mm
8	Width	1624mm
9	Outside Spread of Fork Arms	1500mm
10	Track Front	1395mm
11	Load Centre Distance	600mm
12	Overhang Front	325mm
13	Wheel Base	1350mm
14	Overhang Back	153mm
15	Length From Face of Fork	1828mm
16	Approach Angle	30°
17	Ramp Angle	28°
18	Departure Angle	30°
19	Forward Tilt	5°
20	Backward Tilt	7°
21	Minimum Outside Radius	1670mm
A	Capacity	4000 kg
B	Unladen Weight	7850 kg
C	Maximum Ground Speed	13 Km/h
D	Gradeability	10%
E	Kubota V2403-T diesel / 3ltr GM LPG	44kW / 48kW
F	Electric's	12 Volt
G	Fork Section	150 x 50 x 1200mm
H	20 x 9 x 16 Front Tyre x 2 (Solid Rubber)	OD 508 / Width 229
I	28 x 12.5 – 15 Rear Tyre x 1 (Super Elastic)	OD 711 / Width 318
J	Standard Colour	Green and Grey
K	Suspension Seat	KAB Model 211

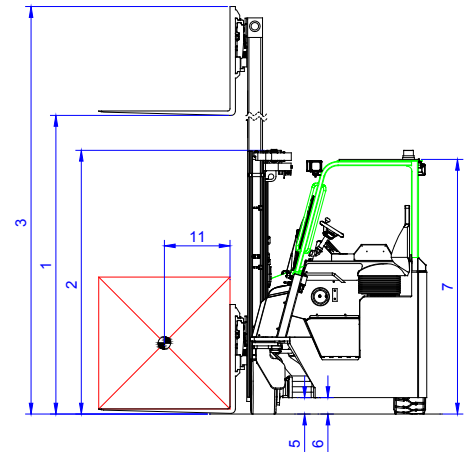

SIDEWARD MODE

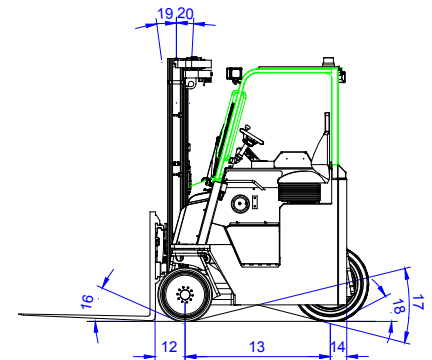
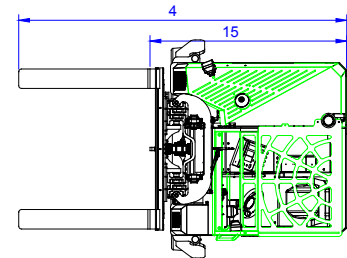

FRONTAL MODE

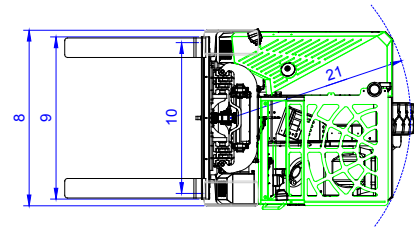

## FEATURES INCLUDE:

- Open cabin
- Load sensing steering
- 4-Way lever positioning of wheels
- Multi-direction operation
- 3 Wheel hydrostatic drive
- 200mm side shift
- Automatic carousel

Distributed by:

**COMBiLiFT**

Co. Monaghan  
Ireland

T: +353 47 80500

F: +353 47 80501

E: info@combilift.com

[www.COMBiLiFT.com](http://www.COMBiLiFT.com)



# COMBiLiFT

Customised Handling Solutions

## COMBi<sup>®</sup>-CBE

Compact multi-directional electric forklift



- > Handles Palletised & Long Loads
- > Operates Indoors & Outdoors

[www.COMBiLiFT.com](http://www.COMBiLiFT.com)



# SPECIFICATIONS

# COMBi<sup>®</sup>-CBE

Protected by Design Registration Copyright: *European Community No.: 000725668-0001 | US No.: D579, 624 | Canadian No.: 123292 | Australian No.: 318370 | Russian Federation No.: 70814 | Korean No.: 30-0516087 | Japanese No.: 1330896 | Taiwan No.: D126056 | Chinese No.: ZL200730329732.6*

Ref.	MACHINE SPECIFICATIONS	STD	OPTION		
1 a	Max. Lift Height	4000mm	4900mm	5500mm	6000mm
1 b	Free Lift Height	0mm	1318mm	1518mm	1718mm
2	Height Mast Closed	2670mm	2243mm	2443mm	2643mm
3	Max. (Mast raised)	4850mm	5778mm	6378mm	6878mm
4	Overall Length	2565mm			
5	Ground Clearance Under Mast	125mm			
6	Ground Clearance to Wheelbase Centre	100mm			
7	Height of Overhead Guard	2250mm			
8	Width	1500mm			
9	Outside Spread of Fork Arms	1325mm			
10	Track Front	1280mm			
11	Load Centre Distance	600mm			
12	Overhang Front	280mm			
13	Wheel Base	1070mm			
14	Overhang Back	150mm			
15	Length From Face of Fork	1500mm / 1550mm			
16	Approach Angle	30°			
17	Ramp Angle	15°			
18	Departure Angle	30°			
19	Forward Tilt	3°			
20	Backward Tilt	5°			
21	Minimum Outside Radius	1400mm			
A	Capacity	2,500 kg / 3,000 kg			
B	Unladen Weight	6500 kg / 6800 kg			
C	Maximum Ground Speed	11 Km/h			
D	Gradability	10%			
E	Battery Capacity	48v / 930Ah			
F	AC Electric Traction Motor x 2	48v / 5kW			
G	AC Electric Pump Motor	48v / 14 kW			
H	Fork Section	125 x 50 x 1065mm Long			
I	16 x 7 – 10.5 Front Tyre x 2	OD 406 / Width 178			
J	22 x 10 x 16 Rear Tyre x 1	OD 559 / Width 254			
K	Standard Colour	Green and Grey			
L	Suspension Seat	KAB Model 211			

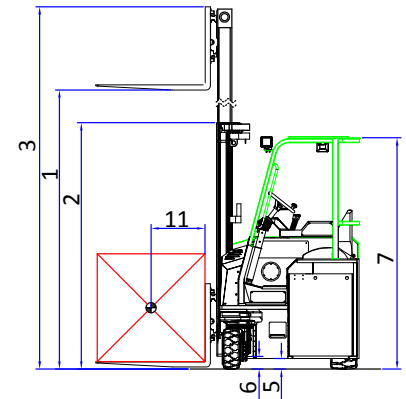

SIDEWARD MODE

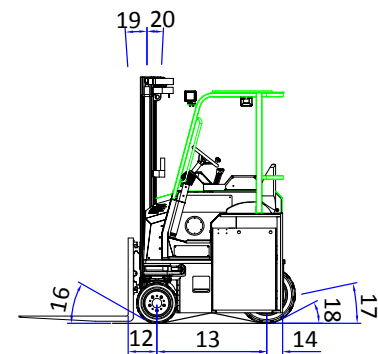
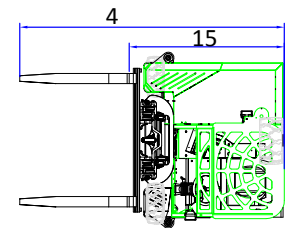

FRONTAL MODE

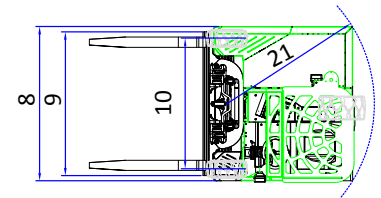

### FEATURES INCLUDE:

- +/- 100mm side shift
- Load sensing steering
- 4-Way lever positioning of wheels
- System Communication via CAN-BUS
- Multi-direction operation
- 2 Wheel Electric Drive
- Powered by AC Technology

Distributed by:

**COMBiLiFT**

Co. Monaghan  
Ireland

T: +353 47 80500

F: +353 47 80501

E: info@combilift.com

[www.COMBiLiFT.com](http://www.COMBiLiFT.com)

(Click me)



Well done, you've find the right multi directional forklift page!

The last clue awaits you: <http://cam.klickdigital.co.uk/clue-3.aspx>